

42" Rechipper



- Long feed spout aids aligning action
- Flat bottom spout
- Long-wearing, easily removable hard-faced steel anvil
- "V" belt drive with extended base included for motor support

ACROWOOD
CORPORATION

42" Rechipper

Available with:

- Bottom or overhead discharge
- Grindable or throw-away knives
- Babbitt type knife adjustment

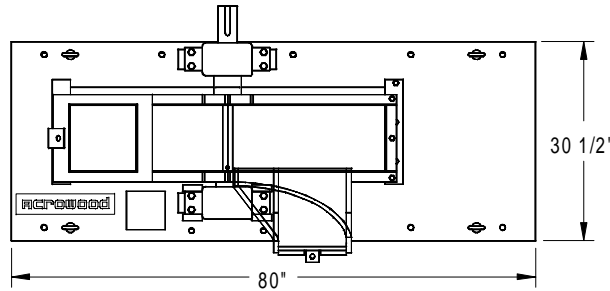

No. of Knives	10
Capacity	15 UPH
Drive Motor	50-125 HP
Approx. Wt.	4,100 lb.

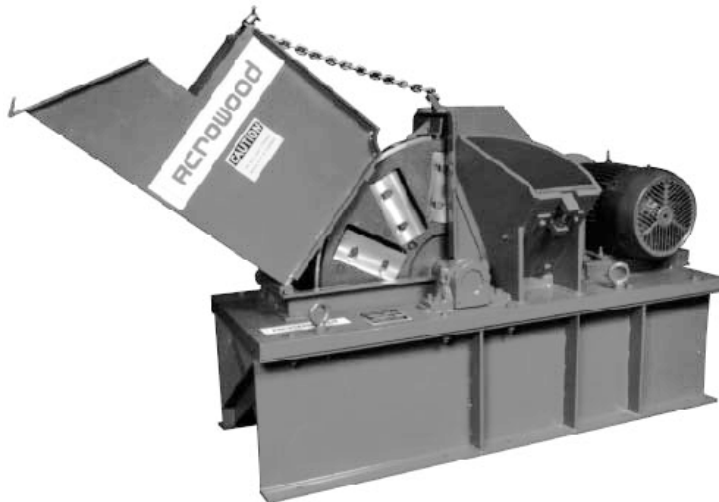
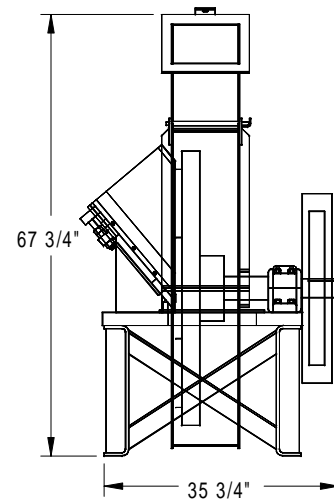
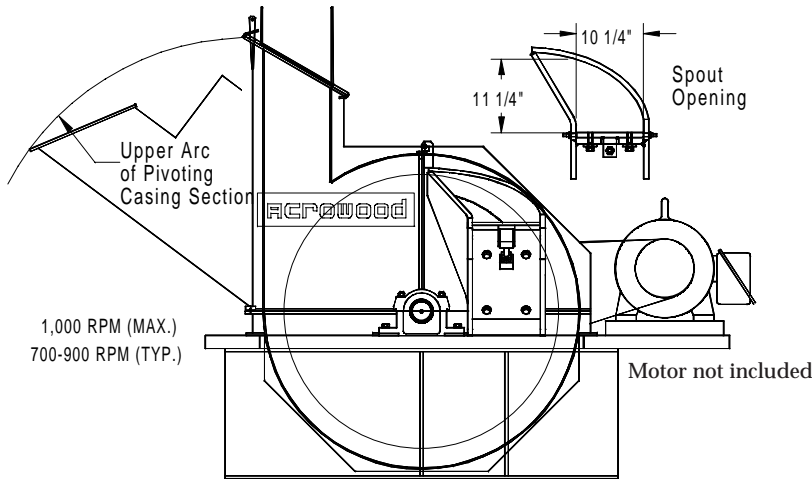

ACROWOOD
CORPORATION

P.O. Box 1028
Everett, WA 98206

Phone: (206) 258-3555
Fax: (206) 252-7622